

TIRION G

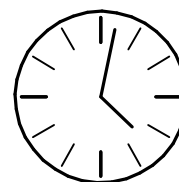

100 min

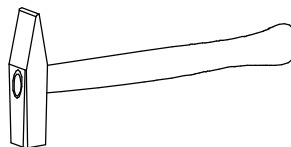

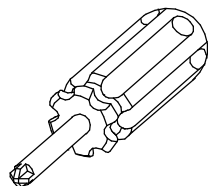
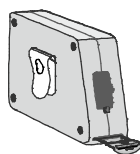
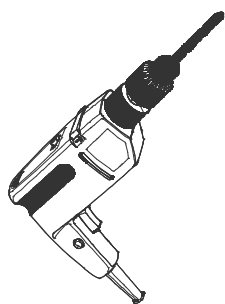
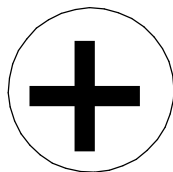
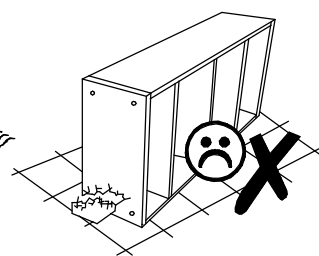
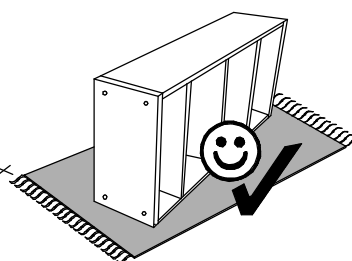
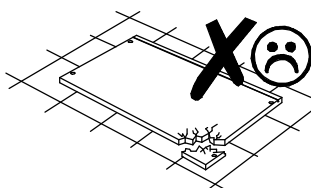
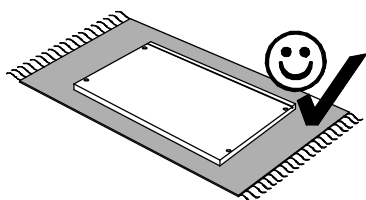
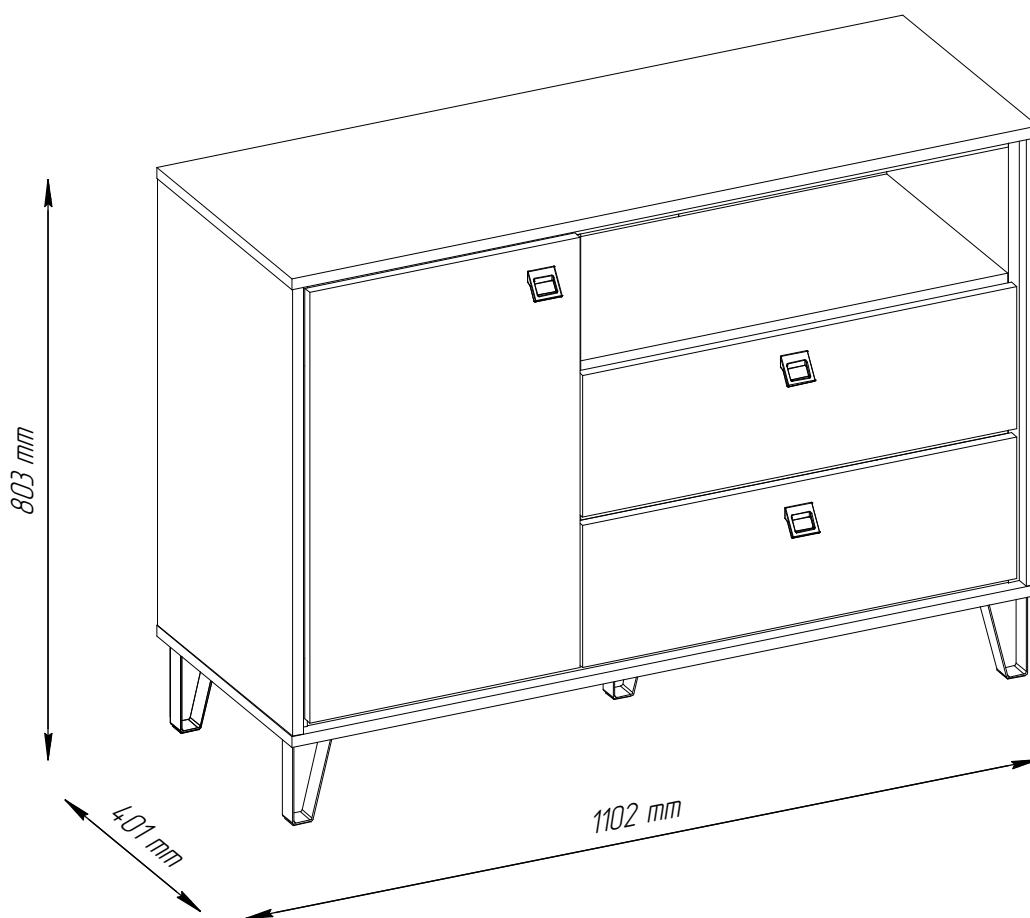
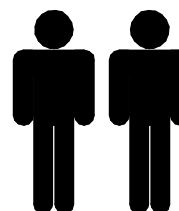
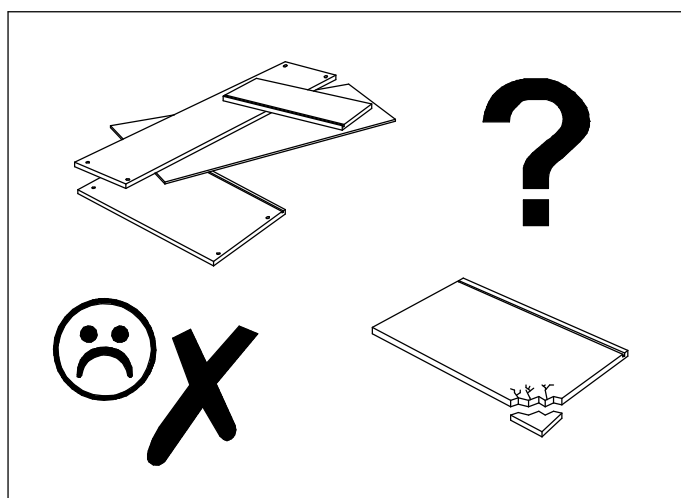
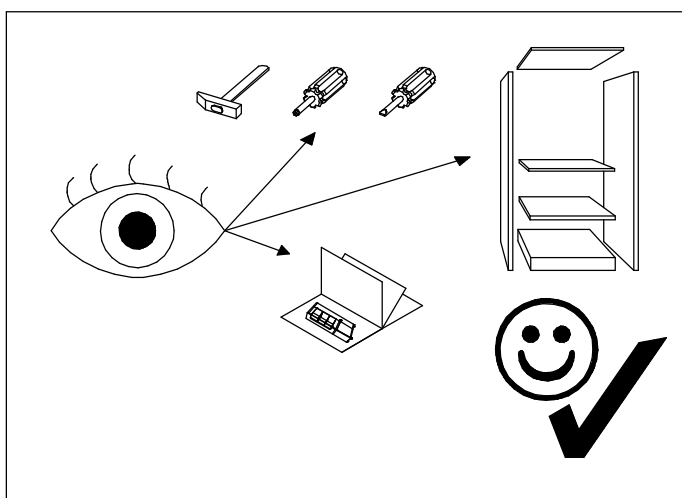
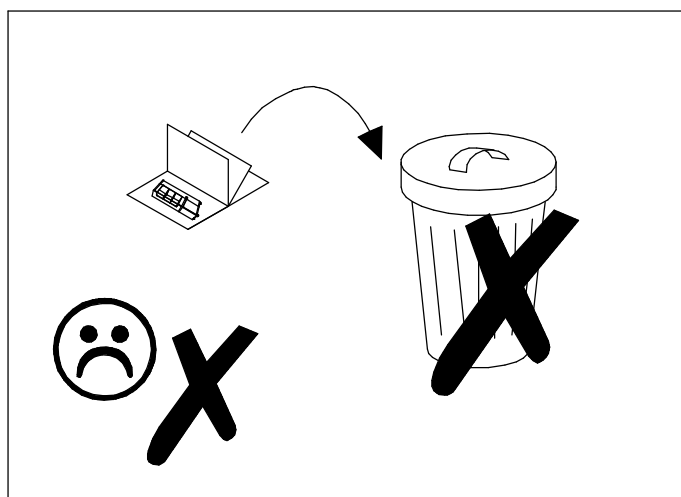
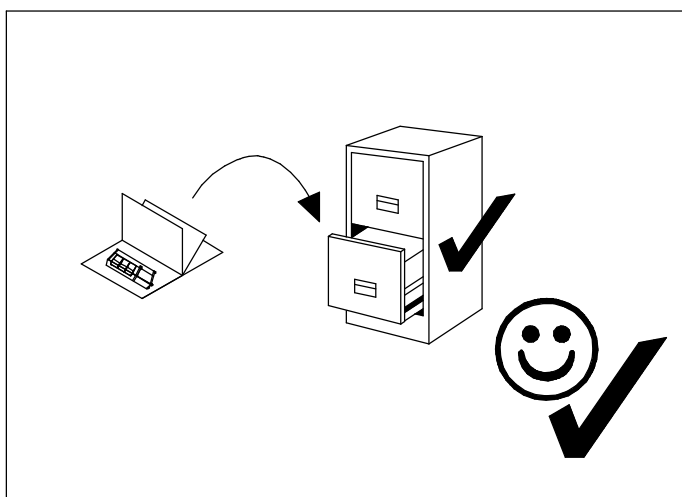
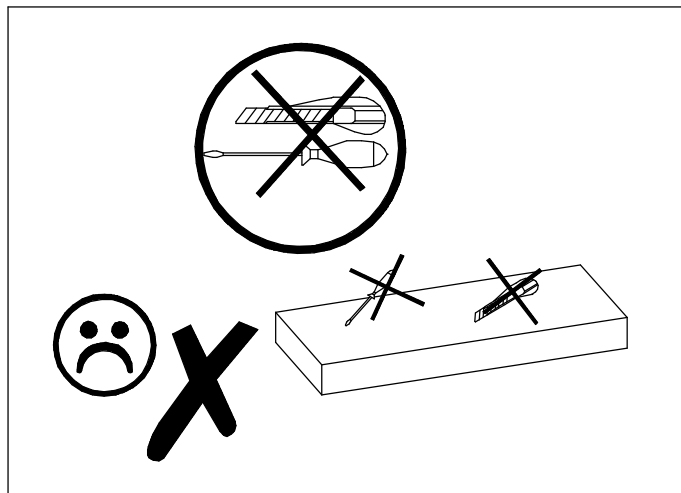
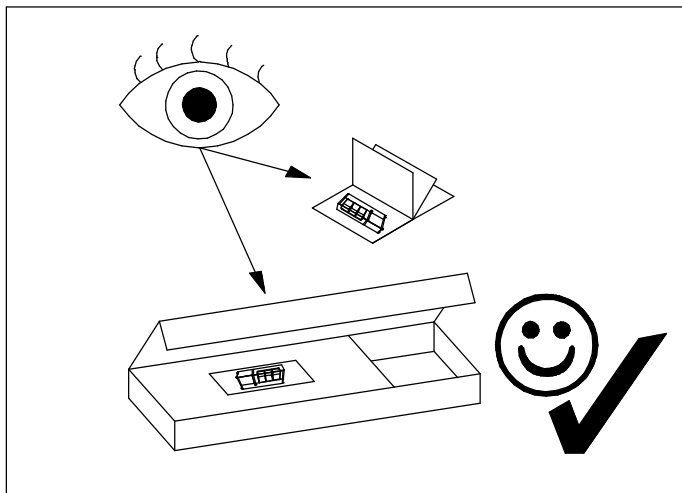

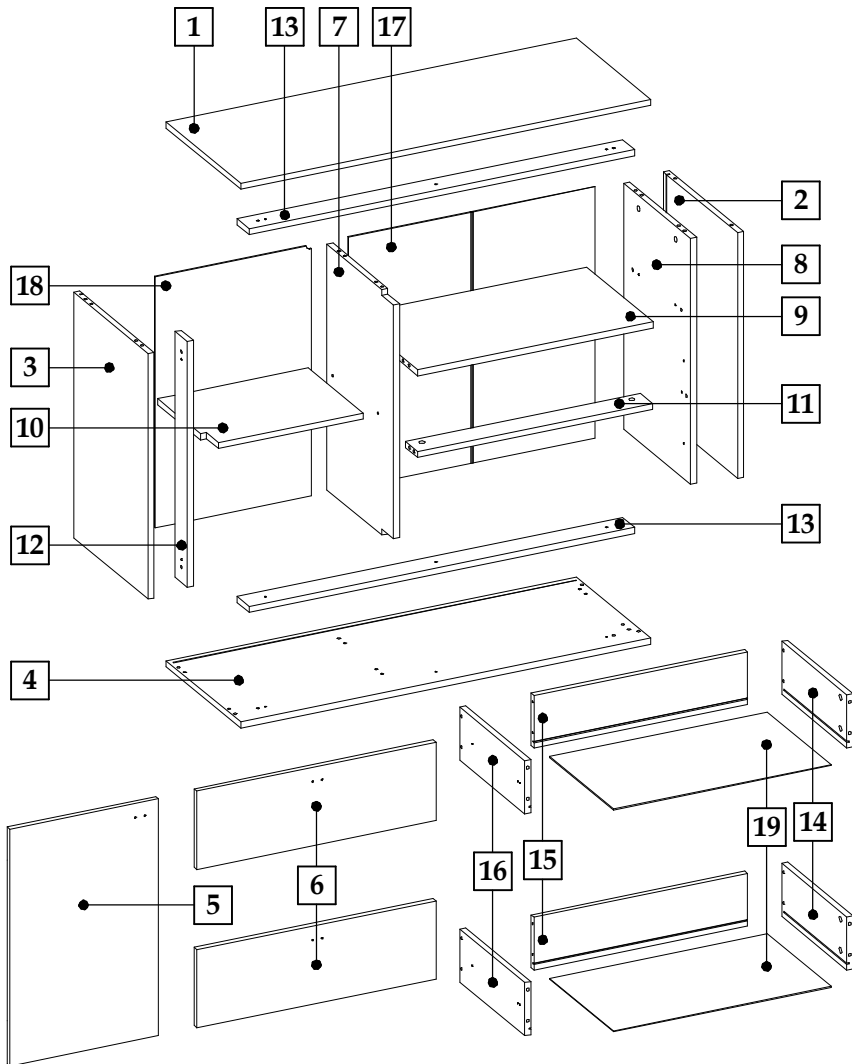
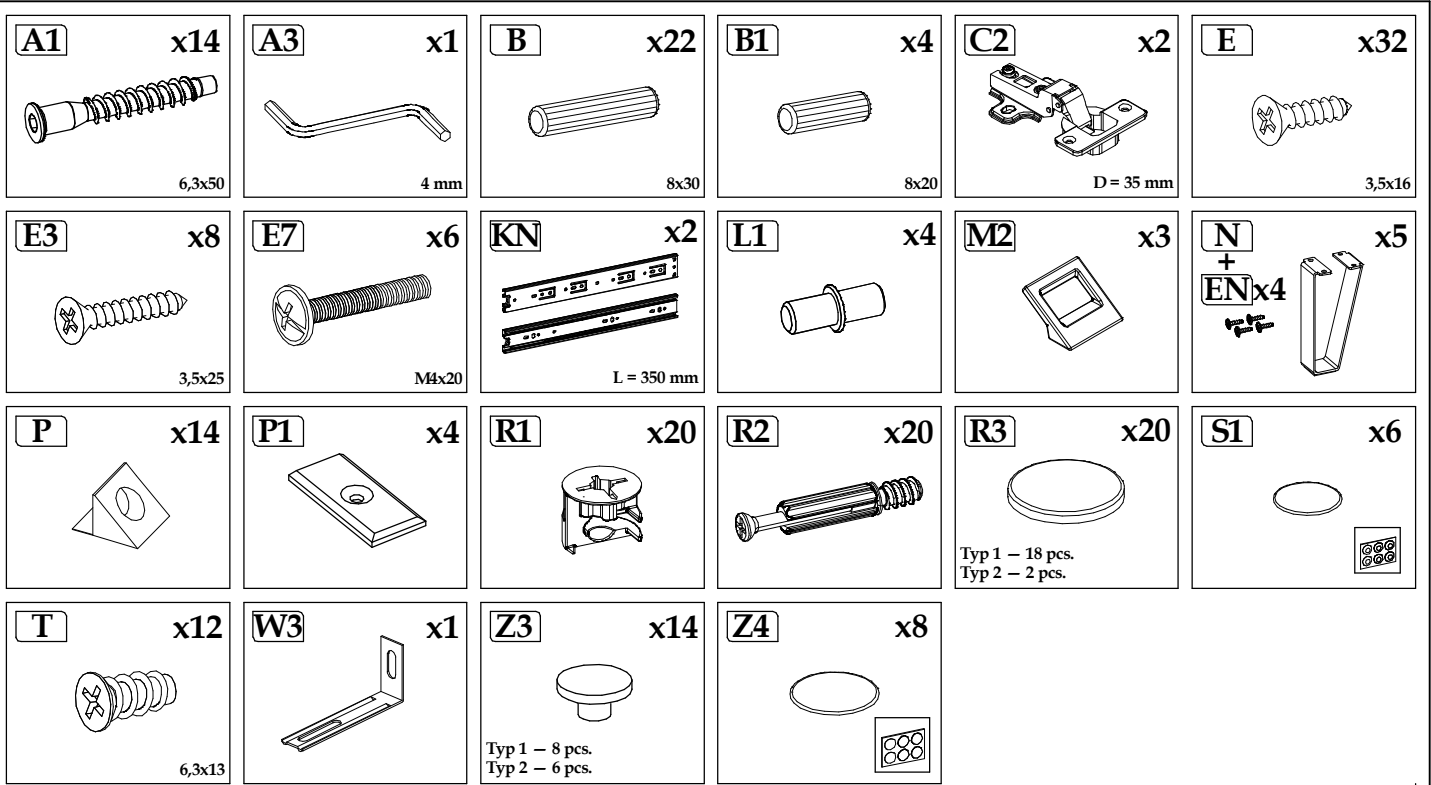

| Element symbol | Measurements | | | | Code | Pack |
|----------------|--------------|-----|----|---|------------|------|
| | 1 | 2 | 3 | 4 | | |
| 1 | 1102 | 401 | 16 | 1 | 1004 | 1/ 2 |
| 2 | 648 | 400 | 16 | 1 | 1001 | 2/ 2 |
| 3 | 648 | 400 | 16 | 1 | 1002 | 2/ 2 |
| 4 | 1102 | 401 | 16 | 1 | 1003 | 1/ 2 |
| 5 | 624 | 399 | 16 | 1 | 1008 | 2/ 2 |
| 6 | 642 | 206 | 16 | 2 | 1031/ 1032 | 1/ 2 |
| 7 | 648 | 359 | 16 | 1 | 1010 | 2/ 2 |
| 8 | 648 | 360 | 16 | 1 | 1009 | 2/ 2 |
| 9 | 631,5 | 358 | 16 | 1 | 1038 | 1/ 2 |
| 10 | 404,5 | 357 | 16 | 1 | N/ A | 1/ 2 |
| 11 | 631,5 | 65 | 16 | 1 | 1037 | 1/ 2 |
| 12 | 648 | 65 | 16 | 1 | 1007 | 1/ 2 |
| 13 | 1036 | 64 | 16 | 2 | 1011/ 1027 | 1/ 2 |
| 14 | 350,5 | 140 | 16 | 2 | 1033/ 1039 | 1/ 2 |
| 15 | 574 | 139 | 16 | 2 | 1034/ 1040 | 1/ 2 |
| 16 | 350,5 | 140 | 16 | 2 | 1035/ 1041 | 1/ 2 |
| 17 | 662 | 333 | 3 | 2 | N/ A | 2/ 2 |
| 18 | 662 | 419 | 3 | 1 | 1050_v | 1/ 2 |
| 19 | 584 | 344 | 3 | 2 | N/ A | 2/ 2 |

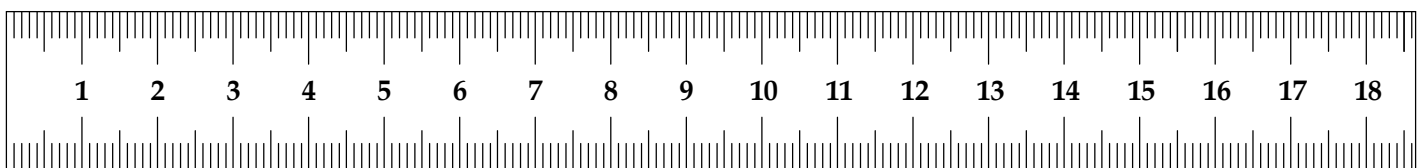

▶ 1

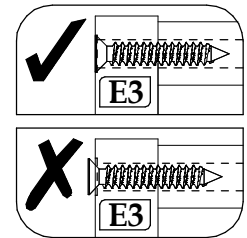
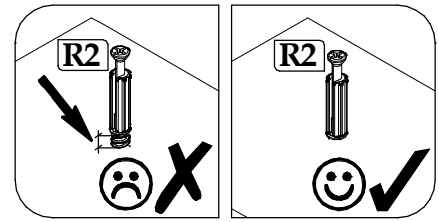
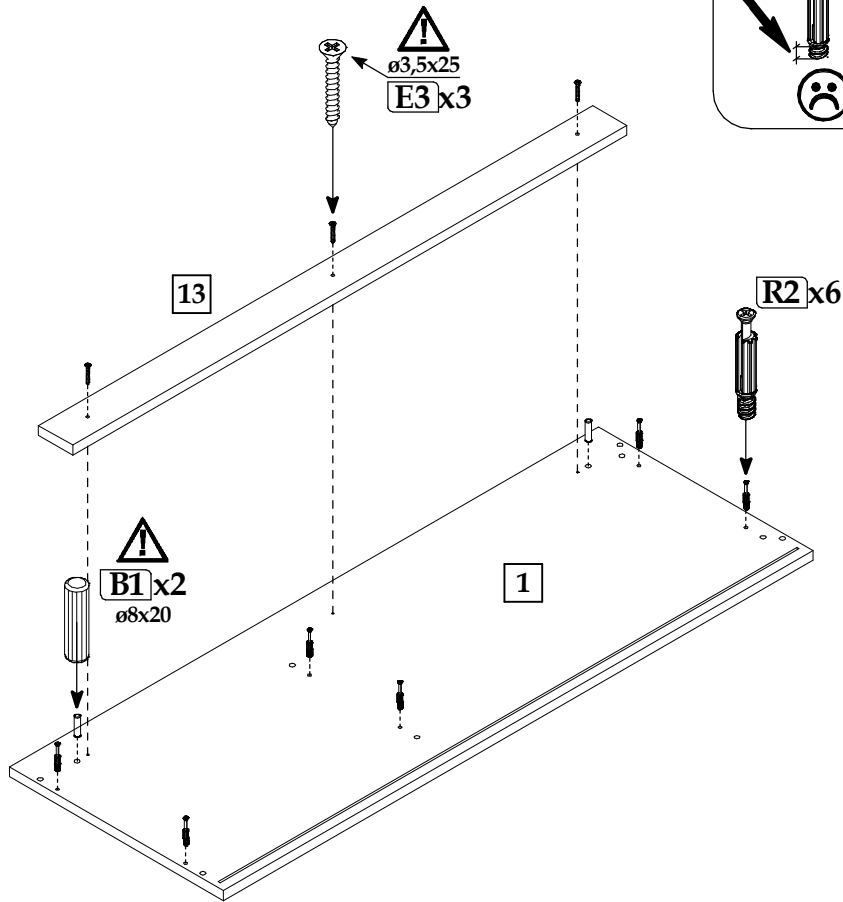

▶ 2

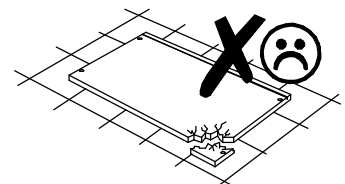
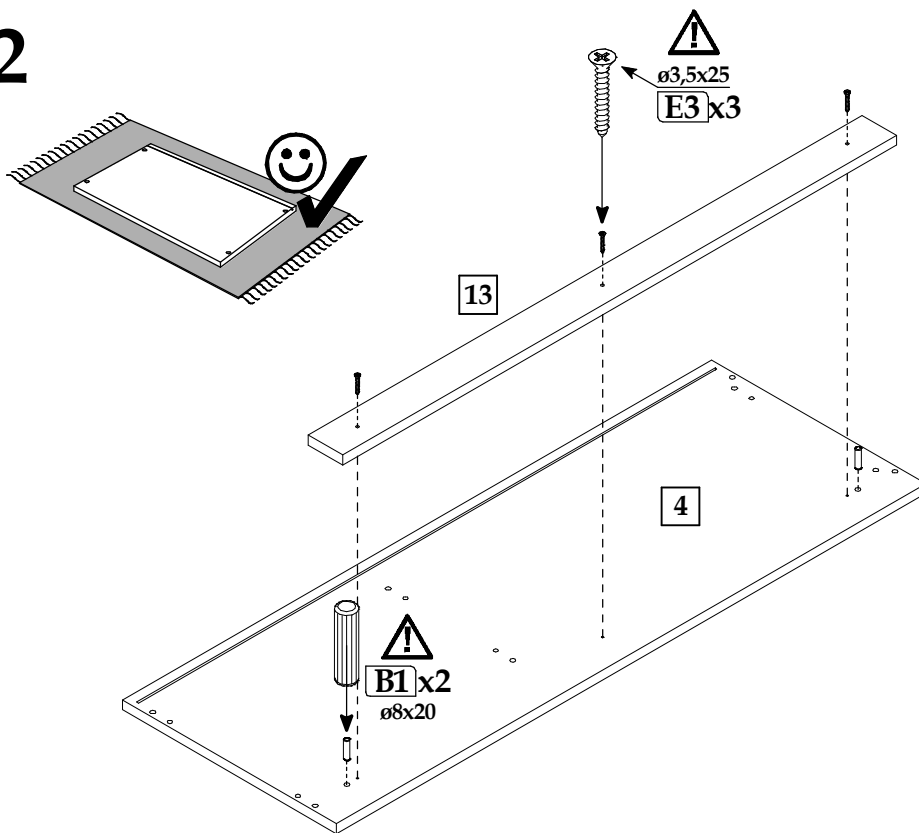

▶ 3

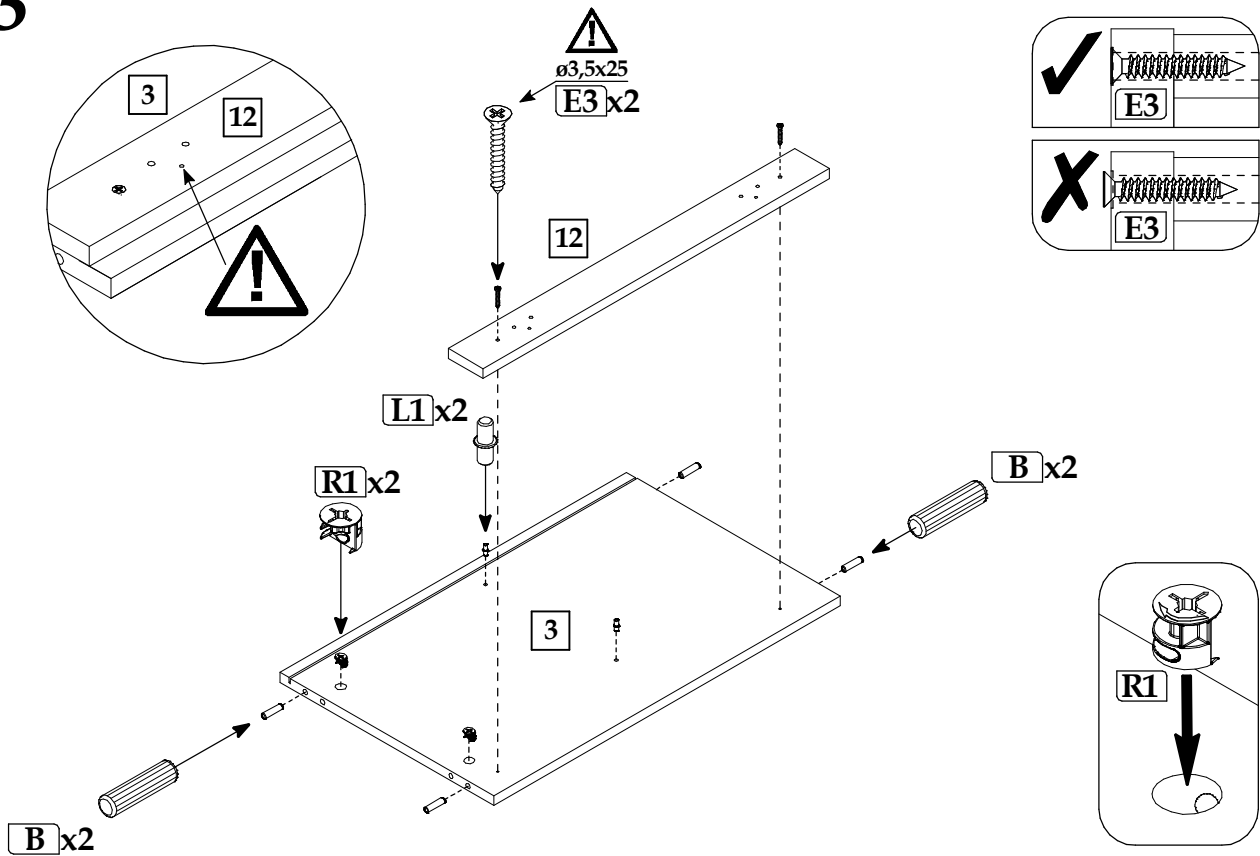

▶ 4

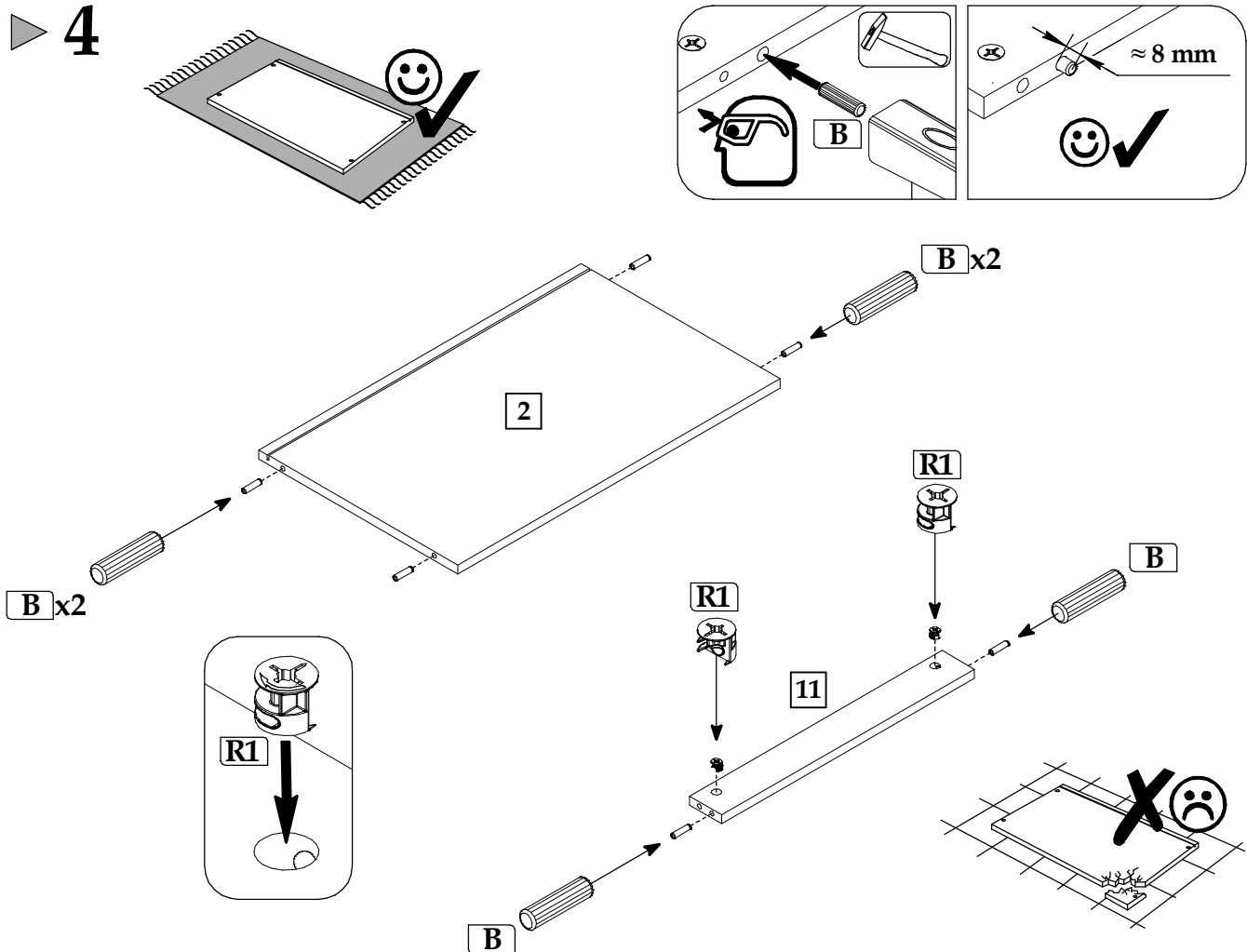

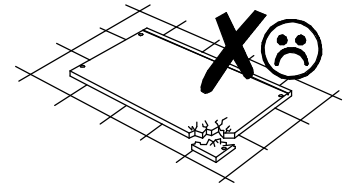
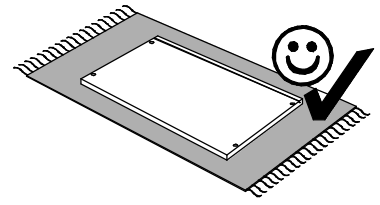
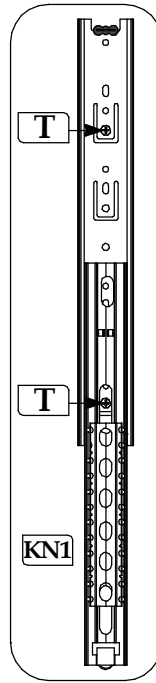
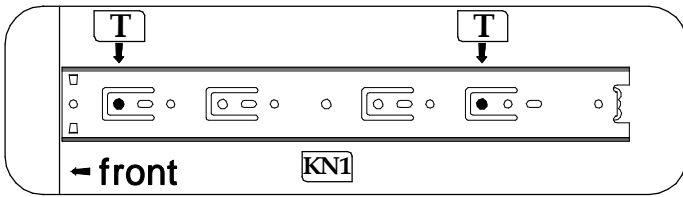
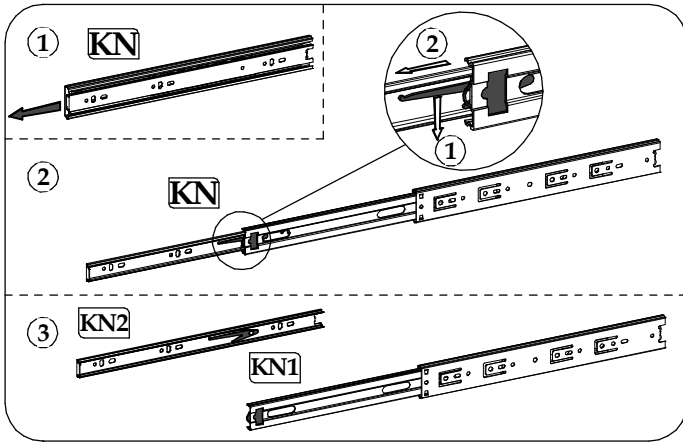

► 5

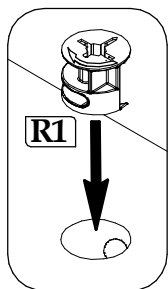
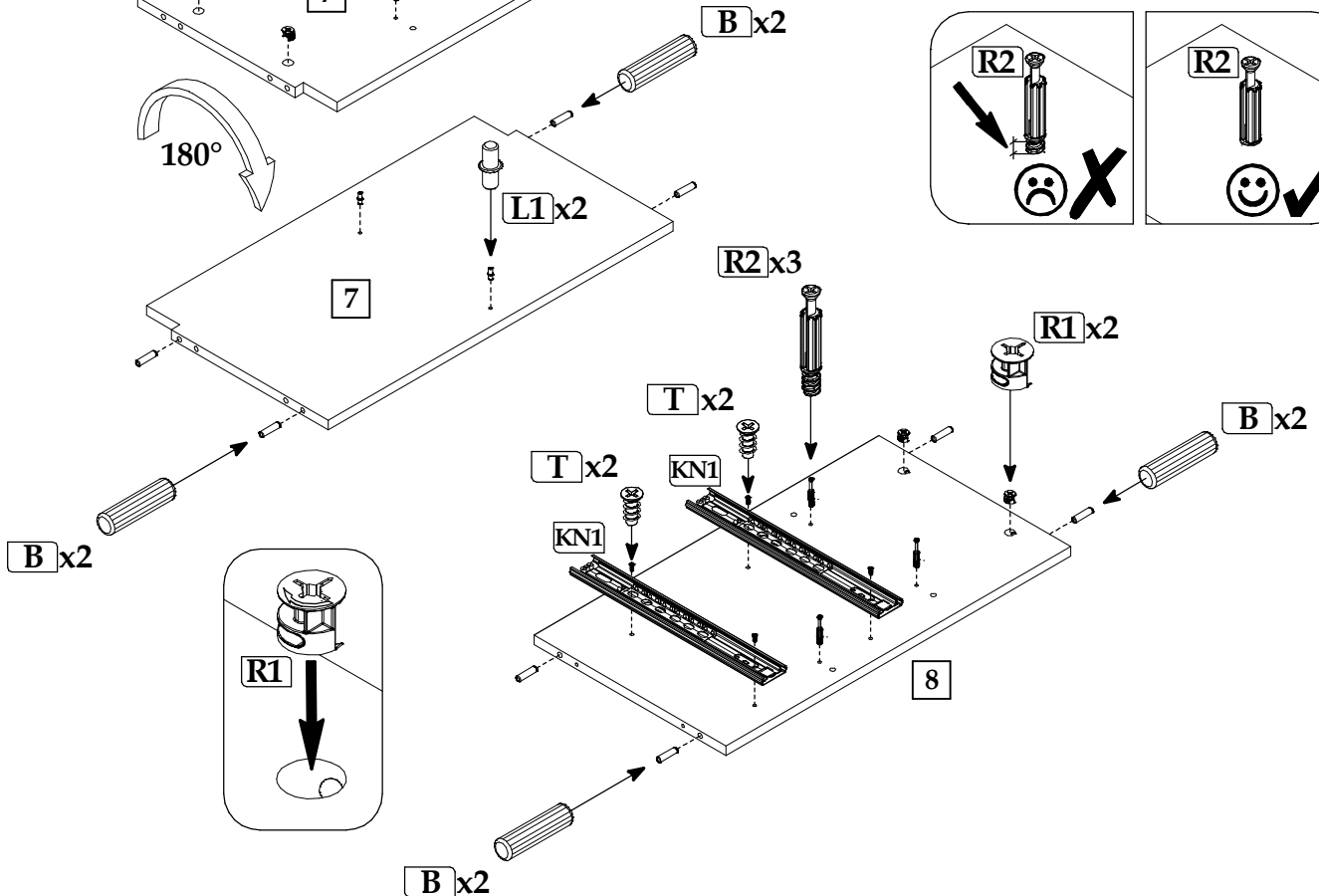
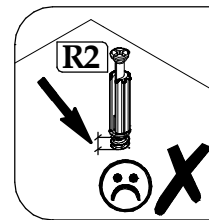
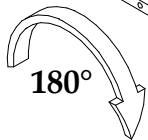
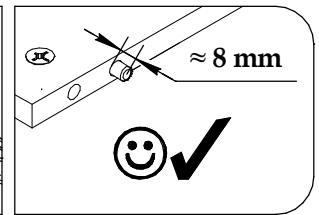
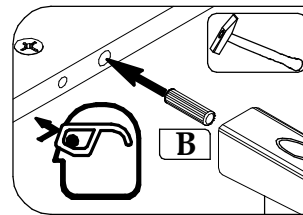
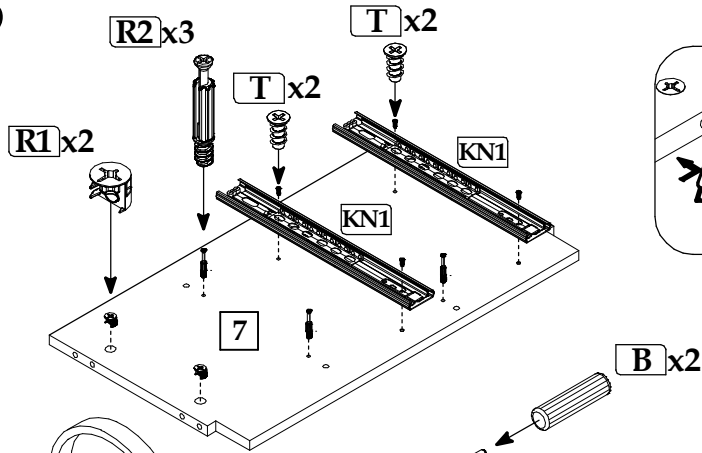

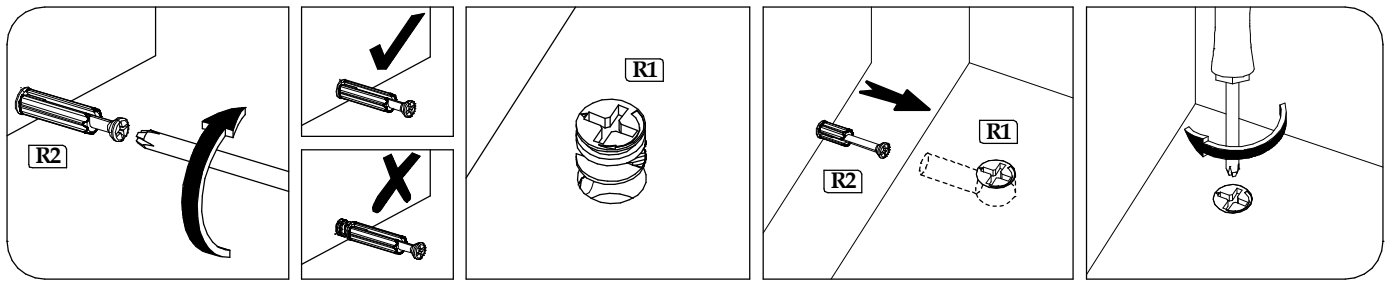

▶ 6

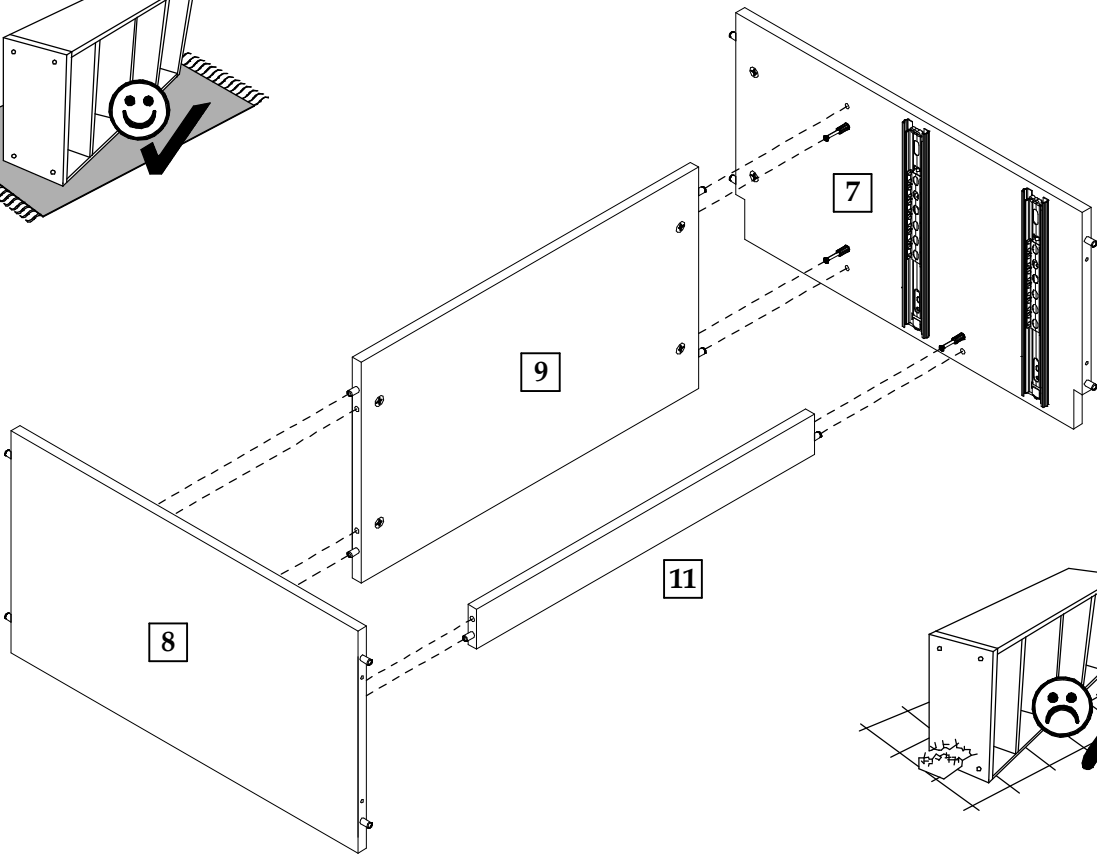
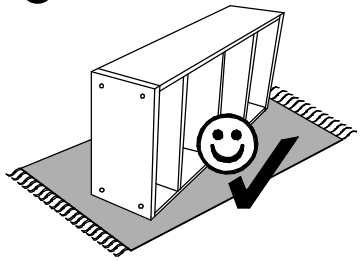

▶ 7

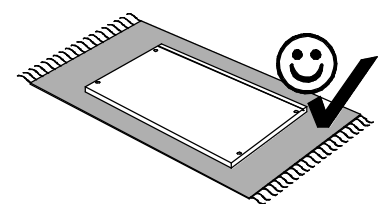
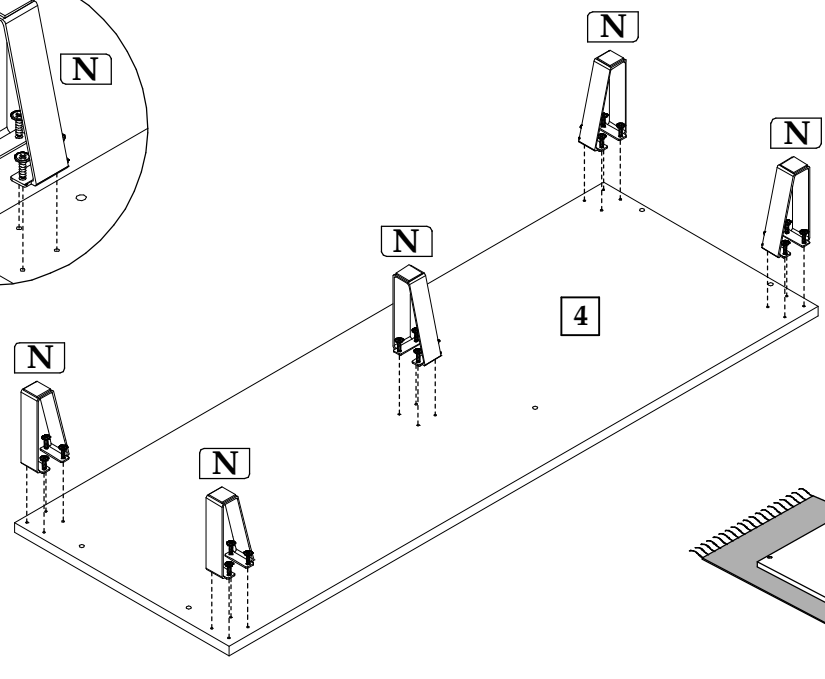
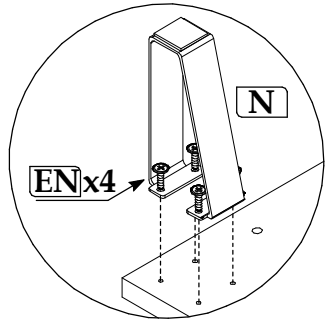

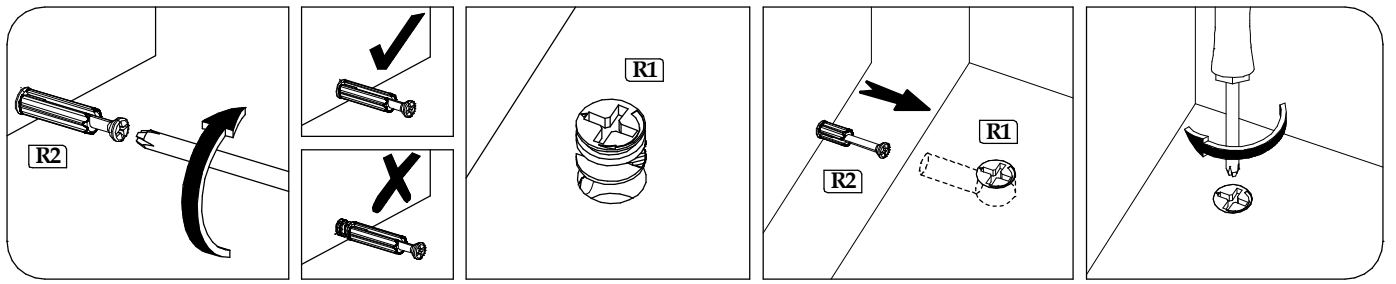

▶ 8

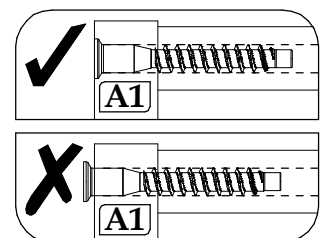
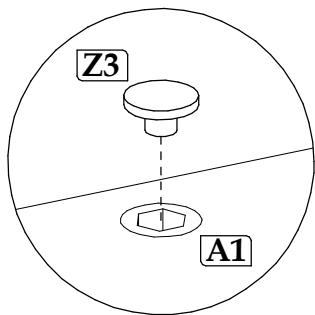
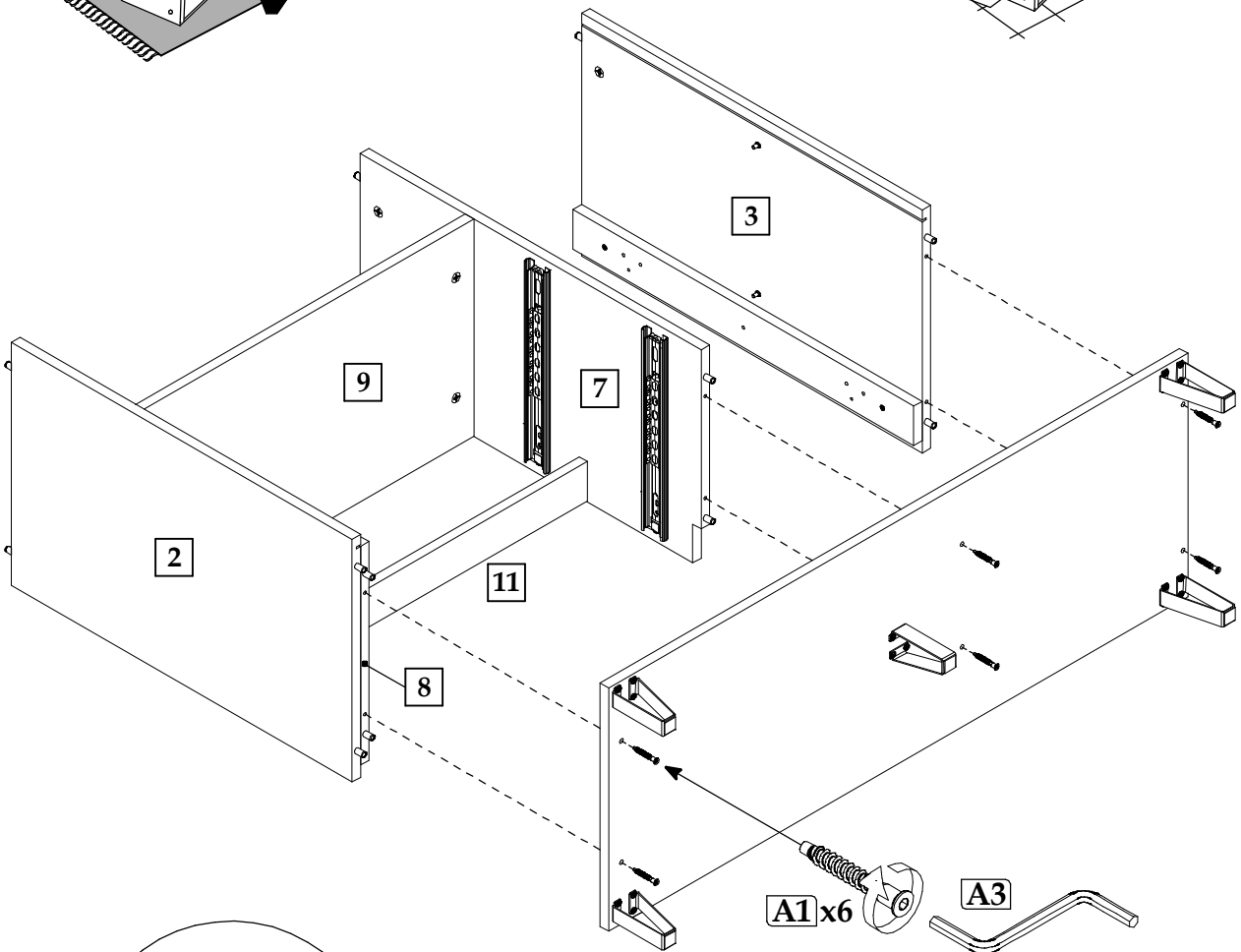
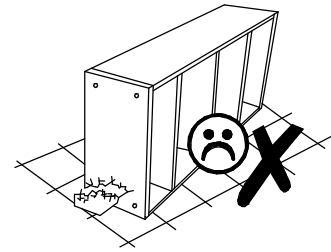
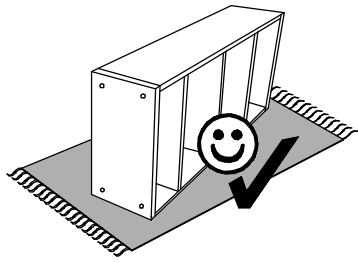

▶ 9

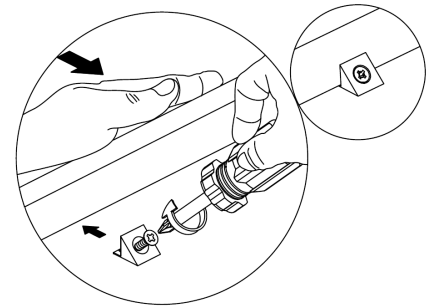
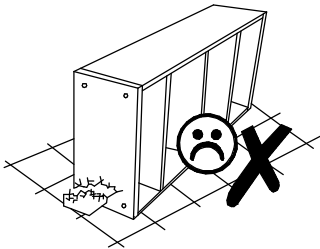
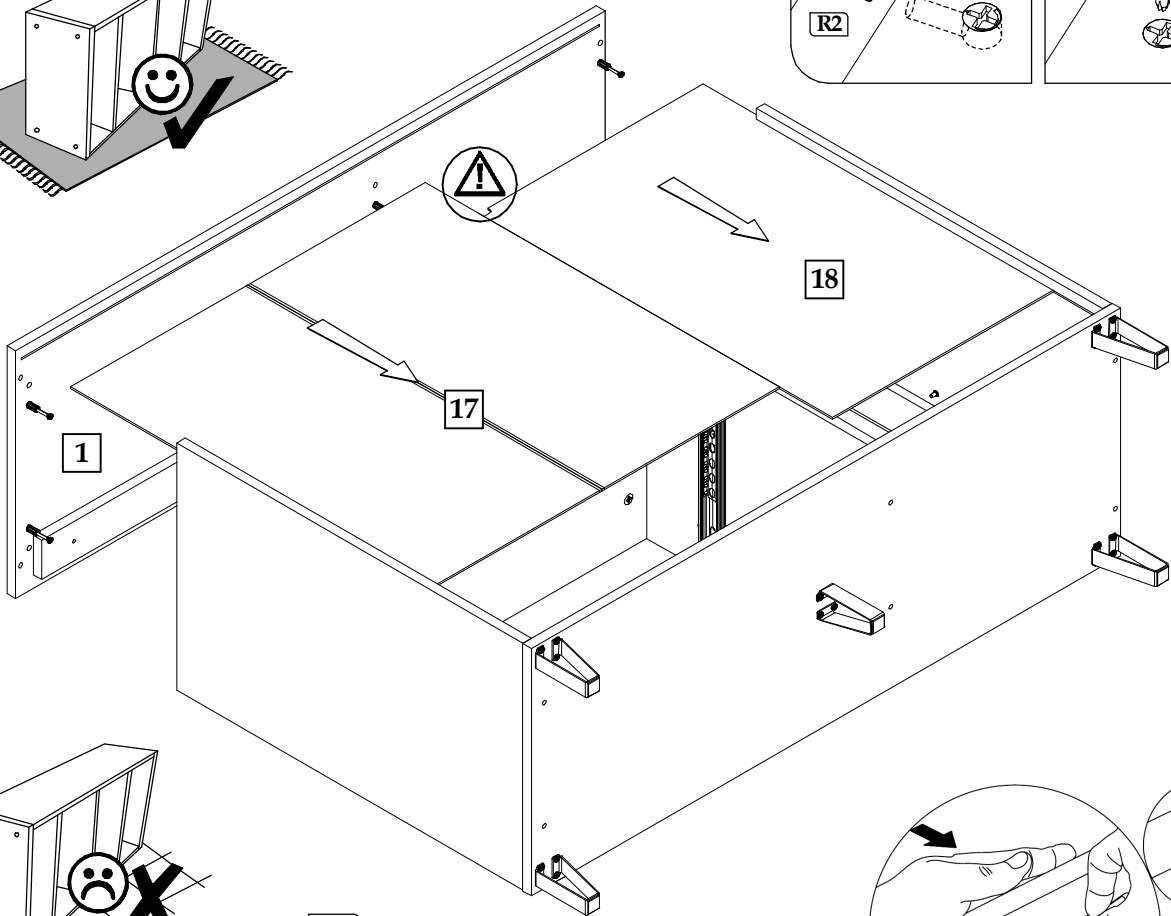
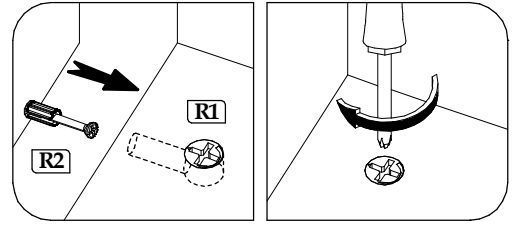
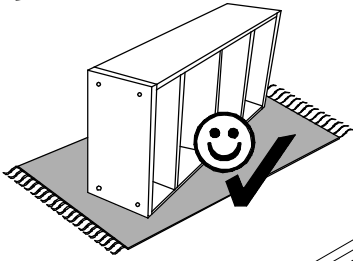

▶ 10

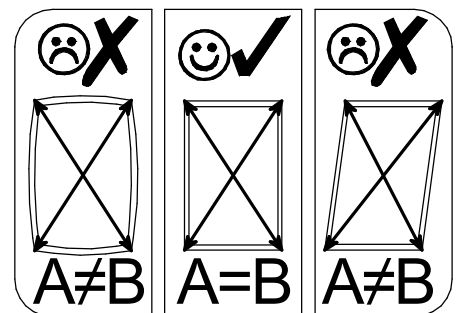
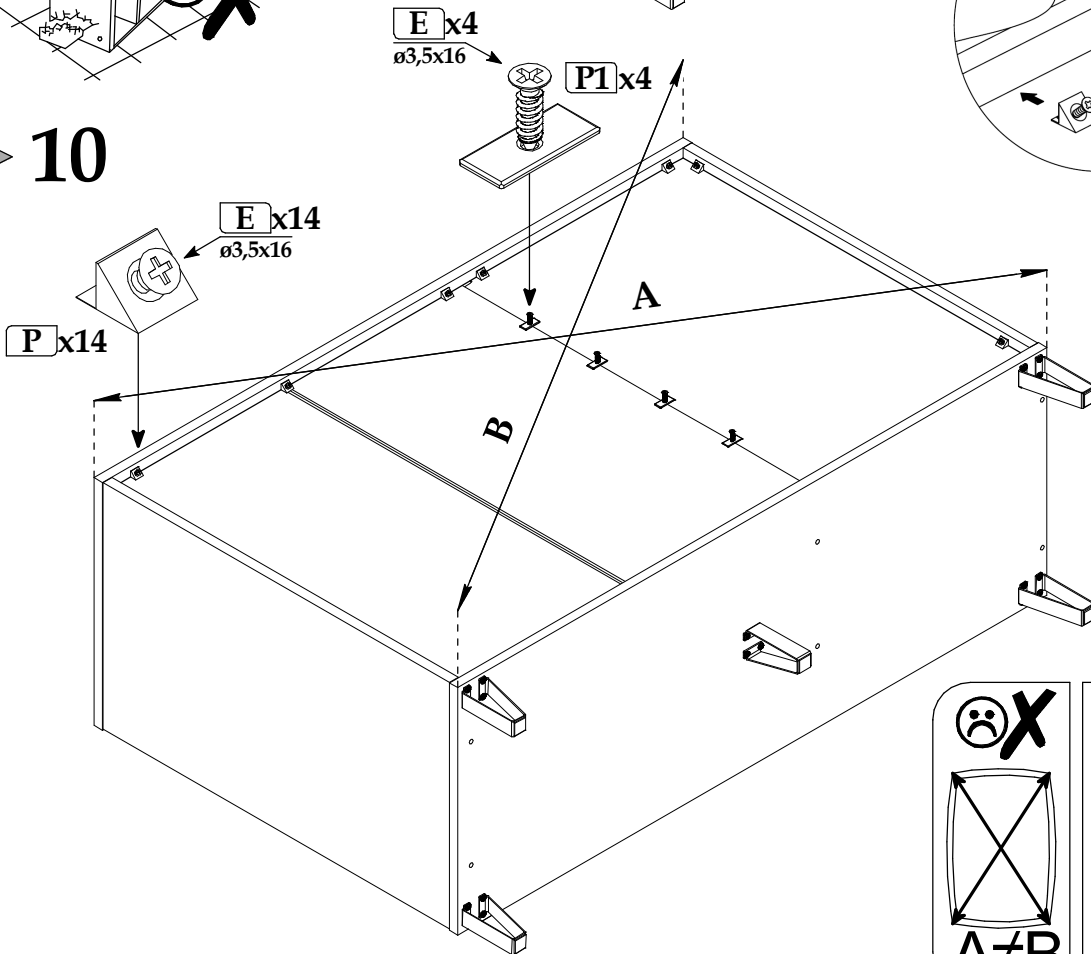

▶ 11

x2

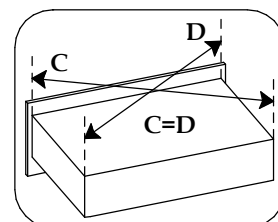
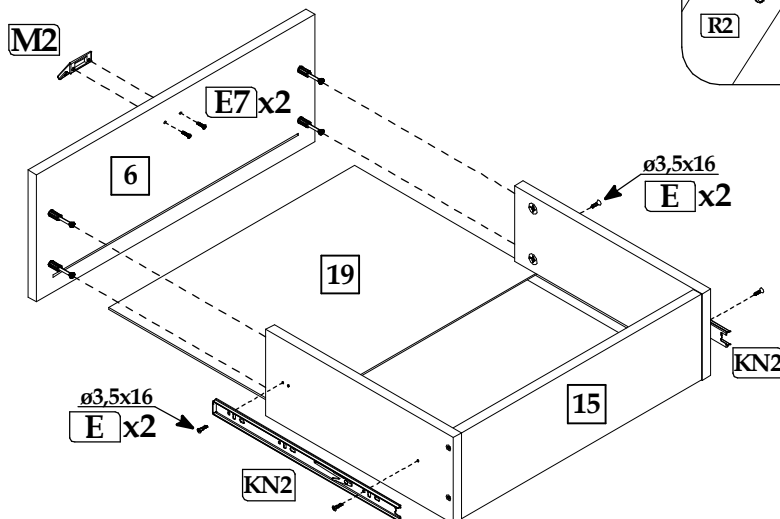
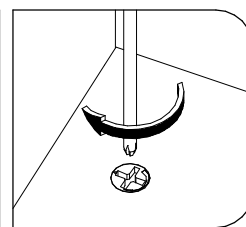
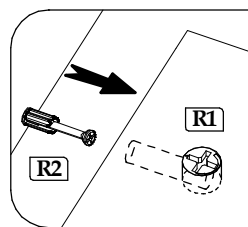
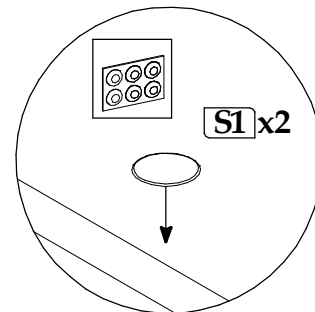
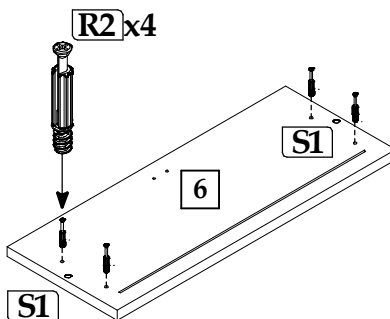
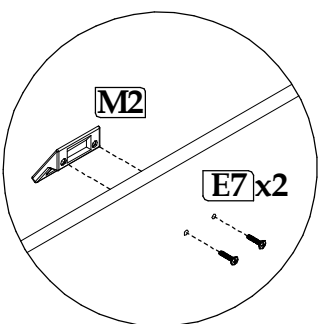
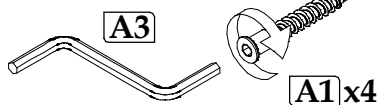
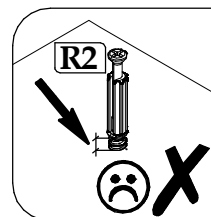
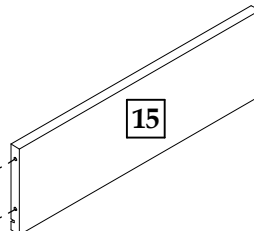
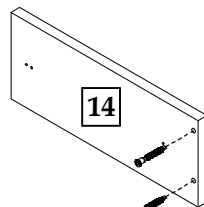
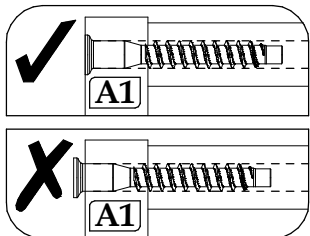
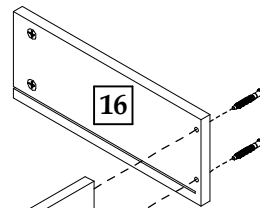
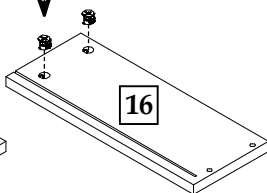
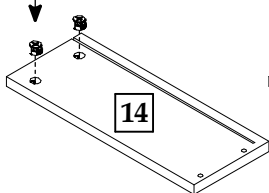
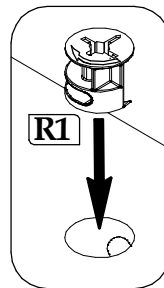

▶ 12

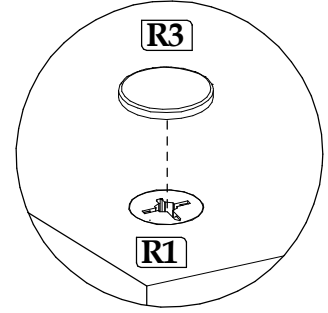
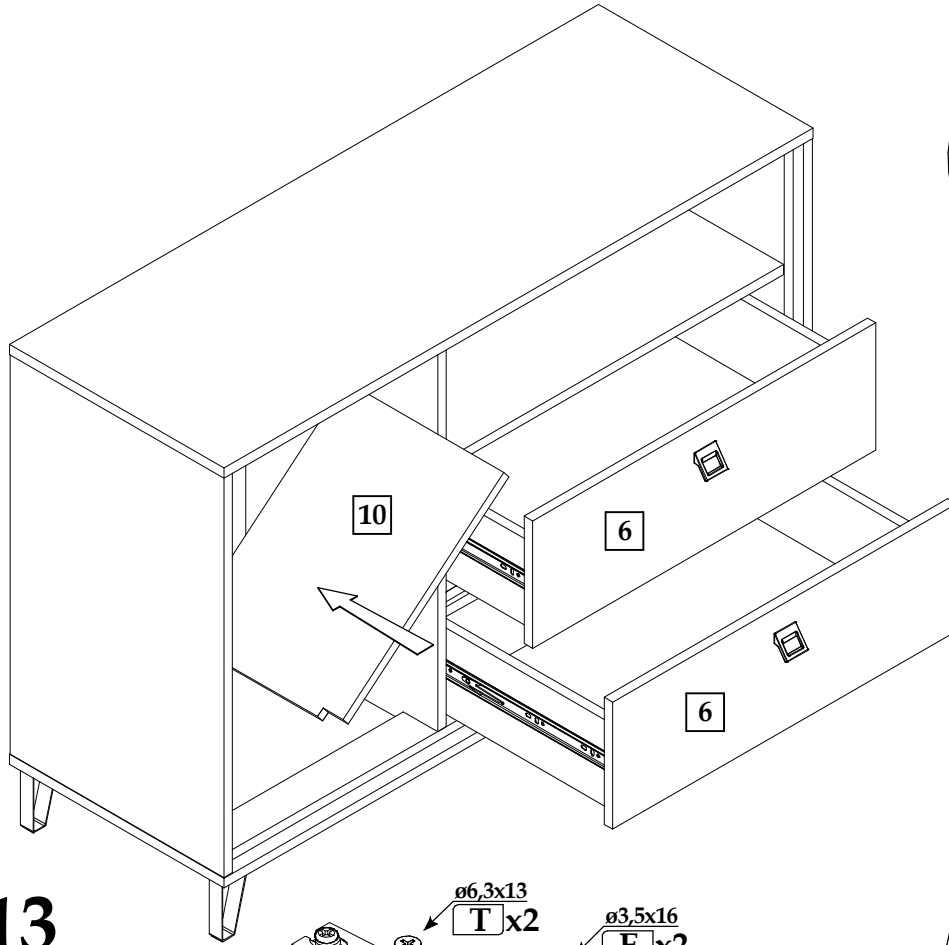
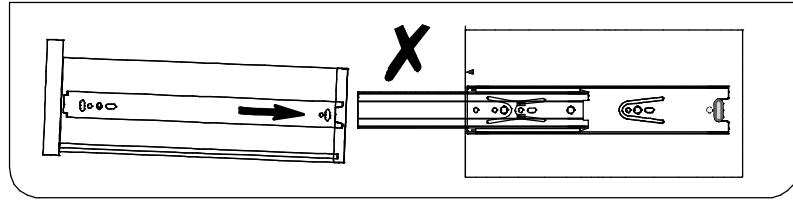
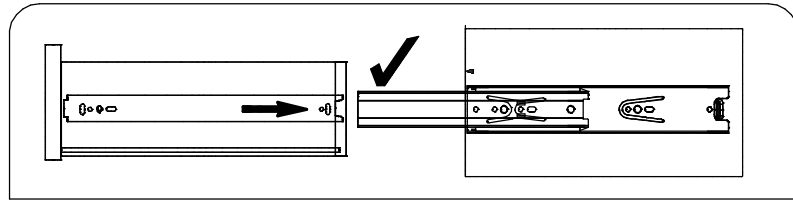
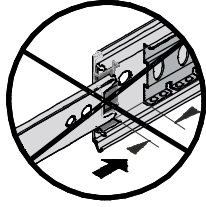
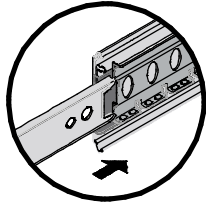

▶ 13

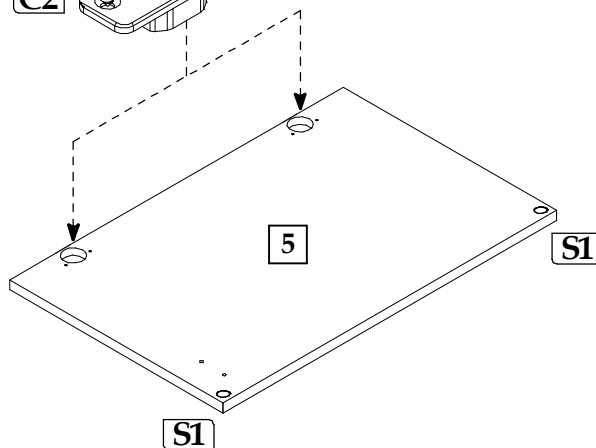
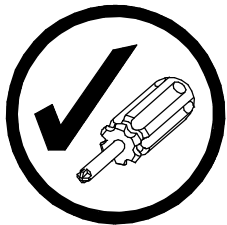
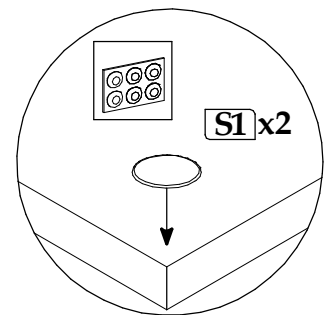
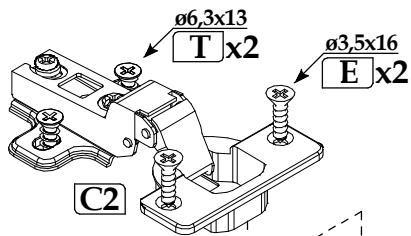

▶ 14

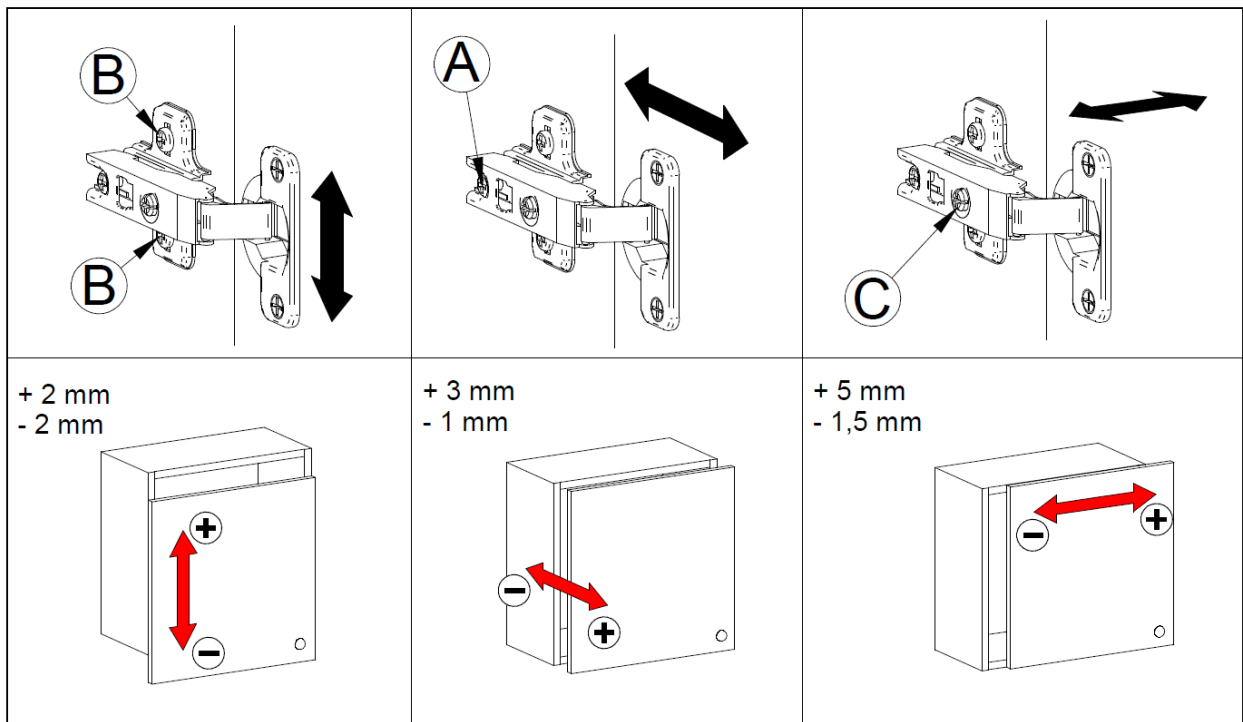
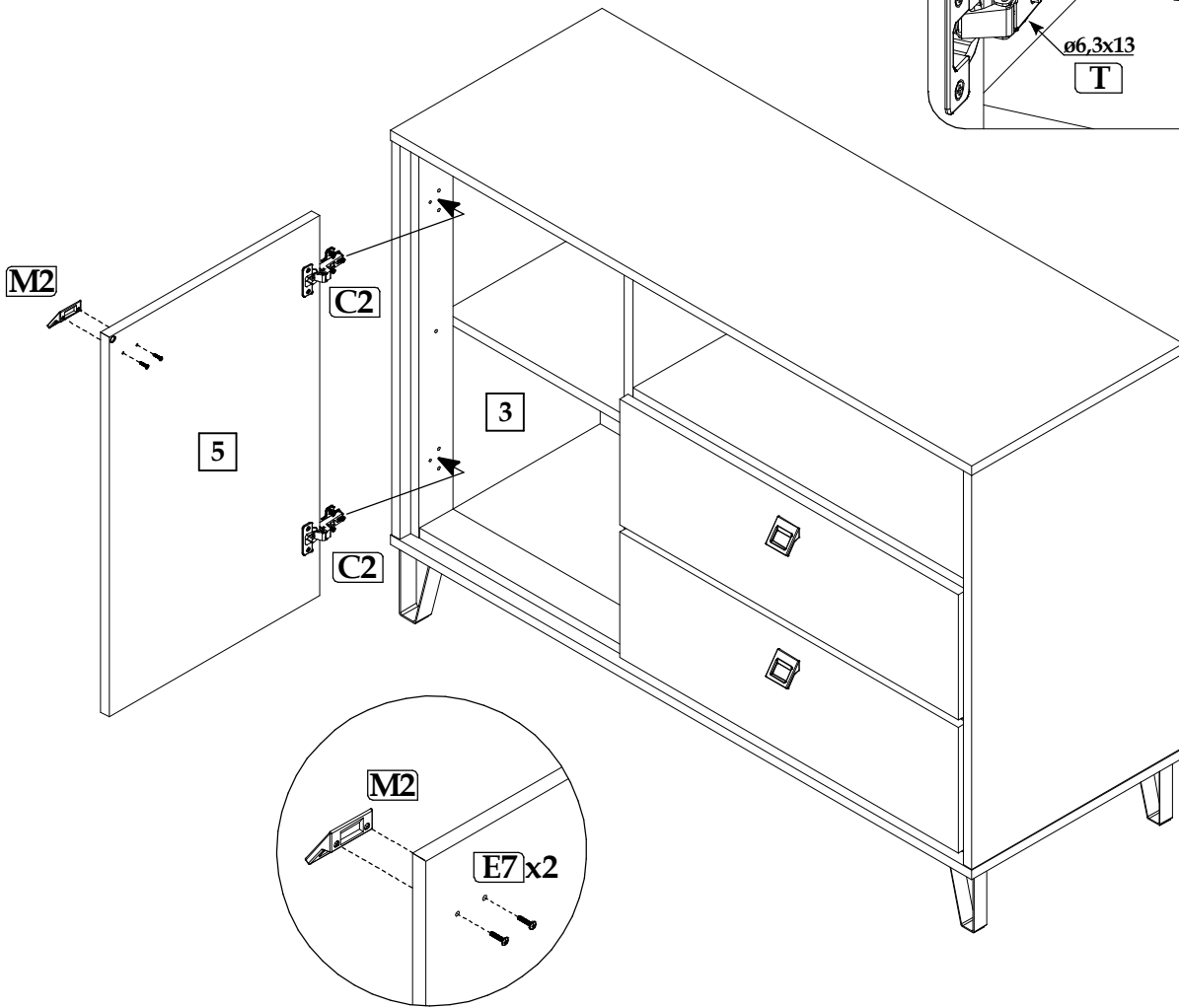
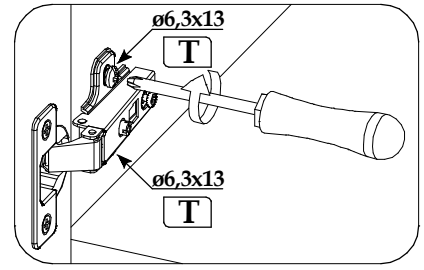

▶ 15

